

# OVHM80

## Air Purifier



# Index

|                               |   |
|-------------------------------|---|
| Important Safeguards.....     | 2 |
| Air purifier Description..... | 3 |
| Function Description.....     | 4 |
| How to use.....               | 5 |
| Maintenance.....              | 6 |
| Troubleshooting.....          | 7 |

# Important Safeguards!

READ ALL INSTRUCTIONS BEFORE USING THIS APPLIANCE.

WARNING: RISK OF ELECTRICAL SHOCK

- Safety precautions should always be used when operating this or any electrical appliance.
- Decrease the risk of electrocution, electric shock, injury or fire by reading and following all of the warnings below.
- To reduce the risk of electric shock, do not attempt to service the air purifier in any way other than to replace or clean the air filter.
- To reduce the risk of electric shock, this equipment has a polarized plug (one blade is wider than the other). This plug will fit in a polarized outlet only one way. If the plug does not fit fully in the outlet, reverse the plug. If it still does not fit, contact qualified personnel to install the proper outlet. Do not alter the plug in any way.
- Read all instructions before operating the air purifier.
- This product operates at 120V AC, 60Hz only.
- Do not run the power cord under carpets, and do not cover with throw rugs.
- This product is not intended to filter oil or grease from air.
- Always unplug the power cord from the electrical outlet when the air purifier is not in use or when changing the filter.
- Never run the air purifier unless it is fully assembled.
- Do not alter the plug in any way.
- Always turn off the air purifier before unplugging the air purifier from outlet.
- Do not place the cord near a heated surface.
- Never operate the air purifier if the plug or cord is damaged or appears damaged. Only qualified service personnel should ever replace or attempt to replace a damaged power cord.
- Never use the power cord to pick up, carry, drag, pull, or lift the air purifier. Do not pull the cord against or around sharp corners and edges.
- Always remove the plug from its power outlet by holding onto the plug itself and pulling gently.
- Never pull on the cord itself to unplug it from its power outlet.
- Use care when operating the air purifier by keeping all foreign objects, fingers, body parts, hair, loose clothing and jewelry away from openings.
- Never touch the air purifier or its plug when your hands are wet.
- CAUTION: THIS EQUIPMENT SHOULD BE INSPECTED, AND COLLECTOR CELLS SHOULD BE CLEANED IN ACCORDANCE WITH MANUFACTURER'S INSTRUCTIONS, ON A REGULAR BASIS TO PREVENT EXCESSIVE ACCUMULATION OF DUST PARTICLES THAT CAN RESULT IN FLASHOVER OR A RISK OF FIRE

## Note:

Before operating the air purifier, make sure the air filters inside the air purifier are not wrapped in plastic. When the air purifier is plugged in you should hear a beep. Press the Power button to turn it on. If the air purifier does not power on, ensure the front cover is installed correctly.

**Save these instructions!**

# 1. Air Purifier Description

## 1.1 Main Structure

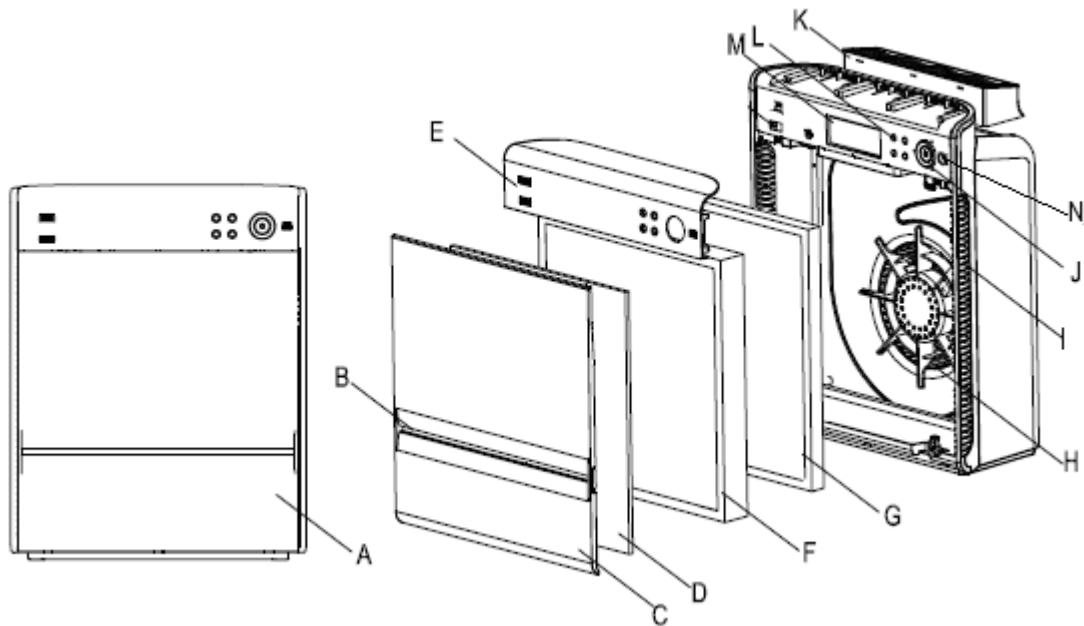

- A. Front view
- B. Front air flow inlet
- C. Front cover
- D. Pre-filter
- E. Front panel
- F. HEPA
- G. Carbon filter
- H. Fan
- I. Side air flow inlet
- J. Power button
- K. Air flow outlet
- L. Function buttons
- M. LED Display
- N. Air Quality sensor

## 1.2 Technical data

120V, 60Hz, 90W, 0.8A

## 1.3 Purifying Process and Main Features

### 1.3.1 Pre- filter

Cleanable pre-filter to capture large particles such as dust. Note: do not soak in water.

### 1.3.2 HEPA filter

HEPA filter to remove microscopic particles down to 0.3 microns in size such as fine dust, smoke, pollen, bacteria and mold.

### 1.3.3 Activated carbon filter

The activated carbon filter consists of a vast system of highly adsorbent molecular sized pores to

remove gases, light odors and VOC s(volatile organic compounds).

### 1.3.4 Anion generator

Low level and ozone safe negative ionizer to freshen and balance the air(ie neutralize a surplus of positive charges from TV's and computer monitors).

### 1.3.5 Air Quality sensor

Measures and displays air quality. In Auto mode, the unit automatically adjusts its fan speed accordingly to deal with the contaminant quickly. The sensor needs about 10 minutes to warm up to reach its maximum sensitivity

The icon of the sensor will flash GAS to indicate the warm-up period and will stay on when ready.

## 1.4 Placement

In order to get better performance in cleaning, it is recommended to place the purifier on the ground or a stable surface around 2 feet high. Since the air is drawn in through the front of the air purifier it can be placed near a wall.

## 2. Function Description

### 2.1 Standby

In standby mode, the standby indicator illuminates in red to show the air purifier has been plugged in and has power but is not operating.

### 2.2 Refresh

Anions are generated under this mode (low level negative ions).

### 2.3 Fan Speed

There are four different fan speeds with Silent the lowest and Turbo the highest fan speeds.

### 2.4 Air quality indicator

There are five levels of air quality indicated as below:

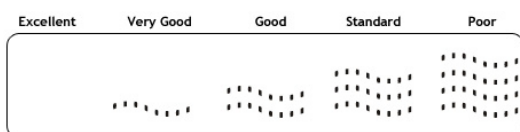

## 2.) '5 i hc

In auto mode, the fan speed of the air purifier will be set automatically based on the air quality detected by the air quality sensor. We suggest setting the fan speed where you like it before pressing Auto. Once pressed the fan will stay at the same speed but the fan speed display will reflect the air quality as in the table below and not the current fan speed. For example, if you on the Strong fan speed and the air is very good the display on the purifier will show Silent even though the fan speed is operating on Strong (speed 3).

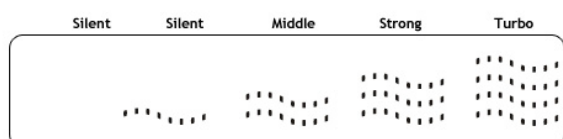

## 2.\* 7\ YW\_ : JHYf

When the purifier has run for a total time of 3,000 hours, the maintenance indicator illuminates to remind the user to check the pre-filter and activated carbon filter. The HEPA filter has a color shade on the frame to see whether it is time to be replaced.

After maintenance, press “Fan Speed” and “Anion” buttons simultaneously for 3 seconds to reset the counter. Please note that whenever the “Fan Speed” and “Anion” buttons are pressed at the same time, the counter will be reset.

If users do not reset the counter after checking the filter or forget to check the filter after 3,000 hours, “Check Filter” will blink after 3,500 hours as a reminder.

## 3. How to Use

### 3.1 Buttons and Displayer

#### 3.1.1 Buttons

ON/OFF, Fan Speed, Timer, AUTO, Refresh

#### 3.1.2 LED Display

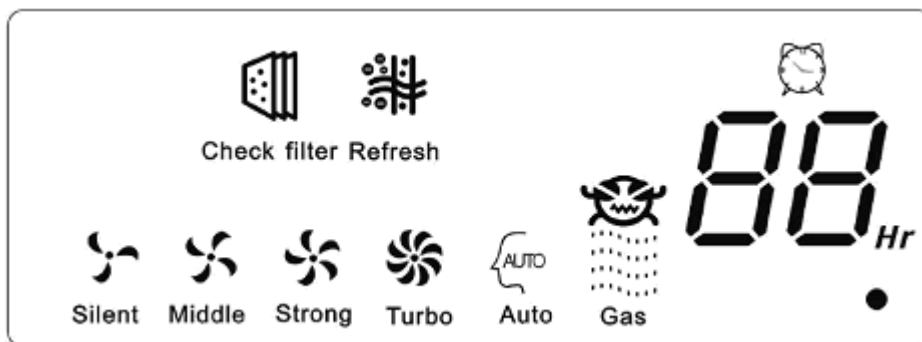

### 3.2 Operation Guide

#### 3.2.1 ON/OFF

Connected with power, the unit beeps with all the display icons illuminating together and enters Standby mode after 1 second.

Press ON/OFF button, the unit starts running at Strong speed. Any time the unit is restarted, it remembers its last working status.

#### 3.2.2 Fan Speed

It controls fan speed and auto function.

The fan speed cycles in the following order:

Strong ---Turbo --- Silent --- Middle

There are indicators in different colors for each fan speed. Silent is green, Middle is blue, Strong is orange and Turbo is red.

#### 3.2.3 Refresh

Press this button and the ionizer starts generating anions. Press this button again to turn off the

ionizer.

### **3.2.4 Countdown Timer**

Press the Timer button to set the number of hours the air purifier will run before turning off. With each press of this button, the time will increase 1 hour and max at 12 hours. Pressing again after 12 hours will turn off the timer.

## **4. Maintenance**

### **4.1 Cover and Housing**

**4.1.1** Power off the unit and unplug before any maintenance.

**4.1.2** Clean the unit only when necessary. If the unit is used in a dirty environment it may need cleaning more frequently.

**4.1.3** Wipe any dust away with a soft cloth (can be dry or damp).

**4.1.4** Do not use any cleaners or chemicals on the air purifier.

### **4.2 Sensors**

**4.2.1** Clean out the dust blocking the sensors' air inlet

**4.2.2** If the sensor is giving a false reading, vacuum around the sensor to remove any dust that may have accumulated there.

### **4.3 Filters**

The filters should be cleaned or replaced regularly.

**Pre-filter:** It's cleanable but DO NOT rinse it. Vacuum lightly or wipe with a damp cloth.

It's recommended to clean this filter every 3 months and replace it after 1 year.

**HEPA filter and Carbon filter:** When the purifier has run for 3,000 hours, the maintenance indicator illuminates to remind the user to check the HEPA and carbon filters. The HEPA filter has a color shade on the frame to see whether it is necessary to replace. Please replace it when the color is dark. After maintenance, press "Fan Speed" and "Anion" buttons simultaneously for 3 seconds to reset the filter replacement indicator.

#### **4.3.1 Disassembly**

1. Front cover: Press in on the front cover at the top two corners to unlatch the interlock switch. Then pull the whole cover upwards to take it off.
2. Pre-filter: Turn the 4 locks per the direction of the arrows to release the pre-filter.
3. HEPA filter: Hold the small ribbon and pull the filter out.
4. Carbon filter: Hold the small ribbon and pull the filter out.

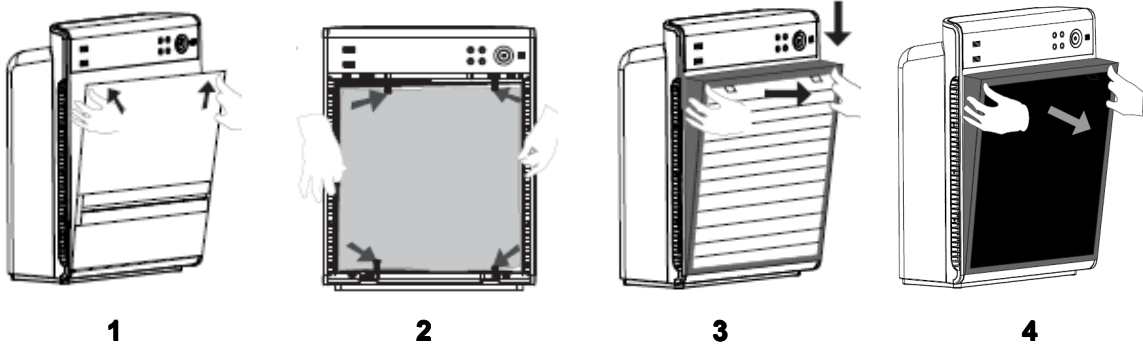

### 4.3.2 Assembly

1. Carbon filter: Put the filter in place from the bottom and then push it into the cabinet.
2. HEPA filter: Put the filter in place from the bottom and then push it into the cabinet.
3. Pre-filter: Place in the pre-filter and turn the locks to secure it.
4. Front cover: Secure the interlock at the bottom first and push the whole cover inwards at the top two corners to secure it.

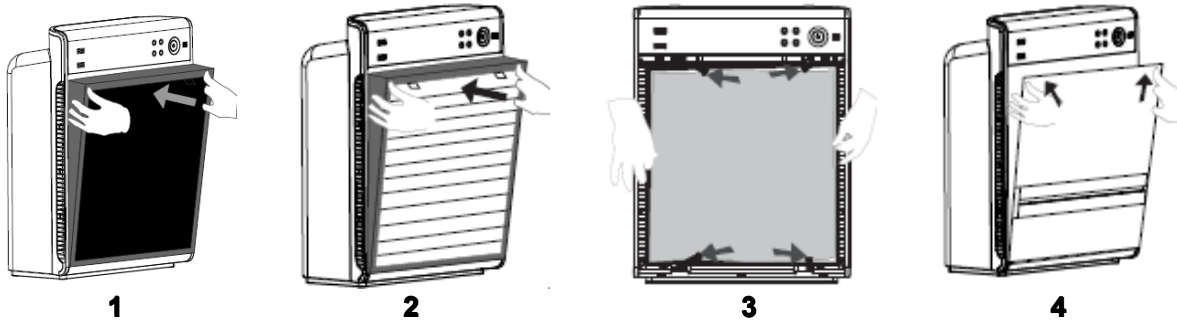

## 5. Troubleshooting

| Problems  | Cause                           | Solution   |
|---|---------------------------------|--|
| Air quality indicator constantly shows poor air quality | Lens inside the sensor is dirty | Vacuum the sensor (right of the power button). Turn off for a few seconds and power back on. |

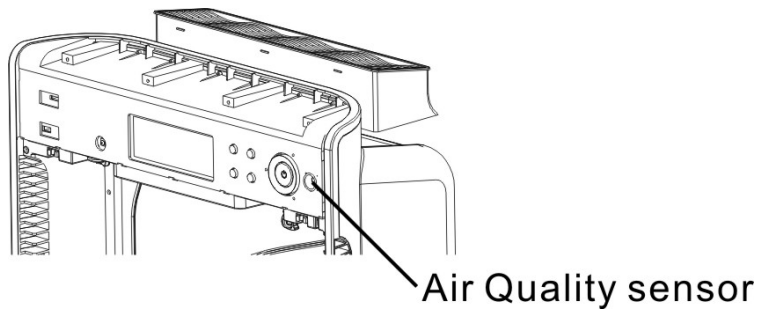

Oransi LLC  
13492 Research Blvd  
Ste 120-507  
Austin, TX 78750

**[www.oransi.com](http://www.oransi.com)**